

THESE INSTRUCTIONS ARE INTENDED FOR TRAINED PROFESSIONALS ONLY. INFORMATION PROVIDED FOR REFERENCE ONLY.

There are many potential hazards associated with sectional garage door installation. These hazards can result in serious injury or death and all precautions should be taken by the installer to minimize the risk of such hazards. Direct Overhead Door Supply LTD is not liable for any damage to the door or persons sustained during the installation of this door. If you are not trained in how to install Overhead doors then please seek the advice of a trained professional. Contact Direct Overhead Door Supply at 403-786-3039, should you wish to discuss best installation practices or seek the advice of a professional.

SAFETY DISCLAIMER: It is the installer's responsibility to identify and minimize potential hazards associated with the installation of this door. Below is a table of identified potential hazards that may be encountered throughout the installation process.

PLEASE READ THESE CAREFULLY and take all precautions to minimize the risk these hazards may pose. Note: potential hazards are not limited to this list.

HAZARD	CONTROL
Working at Heights	Ensure all ladders are checked and placed correctly on level ground. Use a supervisor when working on ladders. DO NOT work on the top rung.
Heavy Lifting	Observe correct lifting techniques when lifting heavy objects. Use 2 people to lift objects heavier than 25kg.
Sharp Edges	Wear appropriate PPE (slash proof gloves) throughout the installation process, especially when handling metal.
Crush Risk	Wear appropriate PPE (steel toed boots) throughout the installation process.
Use of Power Tools	Wear appropriate PPE (gloves, hearing protection, eye protection throughout the installation process. Follow MFG instructions.
Springs Under Tension	Have two people working together when springs are under tension. Ensure door is always secured in a stable position while adjusting spring tension.

PARTS CHECKLIST

SAFETY NOTICE: To install this door properly and safely two people are strongly recommended.

Please ensure that the content of your Sectional Garage Door kit is complete as per the diagram below. If you intend to install this door with operator please ensure that you read the operator manufacturer's instructions carefully before you begin the door installation process.

Parts Checklist

- A - Door panels
- B - Horizontal hockey stick tracks
- C - Horizontal track braces
- D - Vertical straight track
- E - Torsion tube
- F - Top strut (on 16' doors & wider)

Small Parts Box

- G - Spring(s), left and/or right
- H - Side bearing brackets, left & right
- I - Cable drums, left & right
- J - Spring anchor bracket
- K - Lifting cables
- L - Roller axles
- M - Flag brackets
- N - Vertical track brackets
- O - Center hinges
- P - Finger-safe hinge/roller assembly
- Q - Top Fixture
- R - Bottom bracket hinge
- Extras

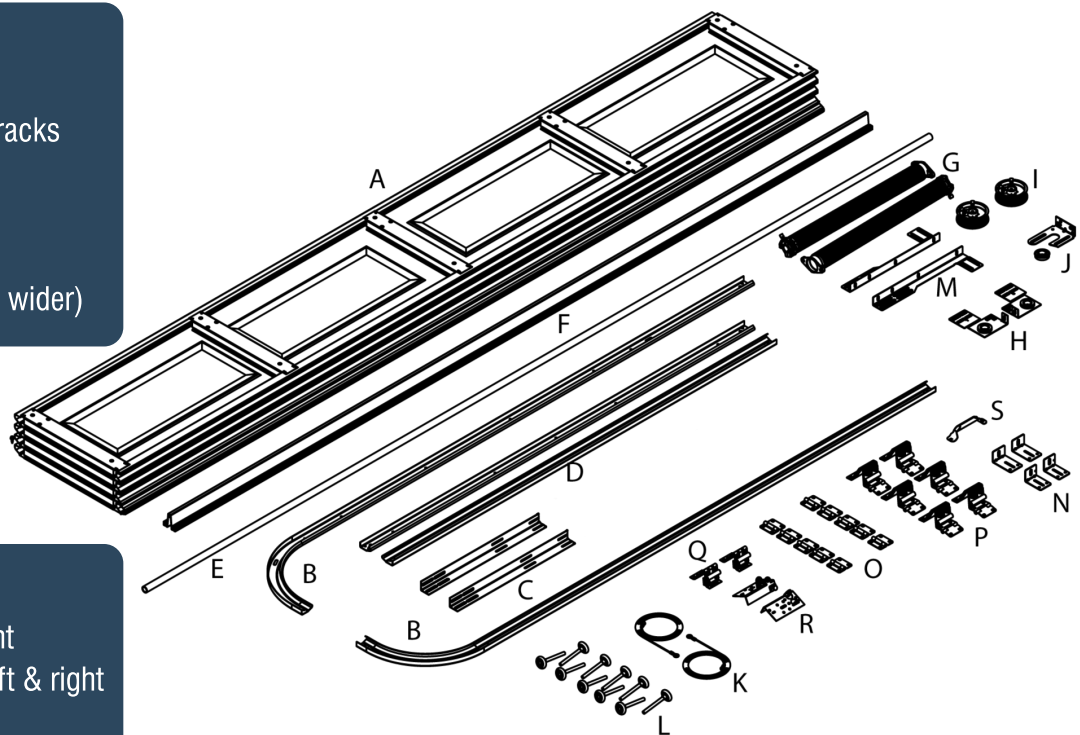

Figure 1.1

NOTE: 5/16 x 1/2" lag screws are supplied as standard fixing with Sectional Doors. Should you be fixing to a non-wood frame, please ensure you have the correct fixings appropriate for the material.

NOTE: All instructions are from the inside looking out.

Ensure that the door opening and the supplied door will fit. This can be done by measuring the height of all panel and adding together.

Ensure that you have at least 5" of side room on each side and 14" of head room before you continue.

The backspace should be the door height, plus 3' to allow for operator and door height 6" for a manual door.

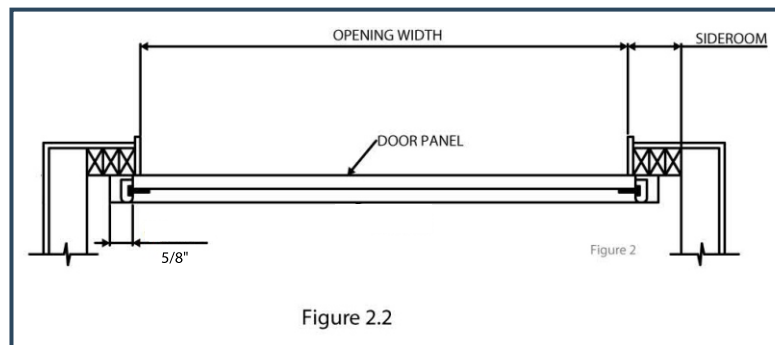
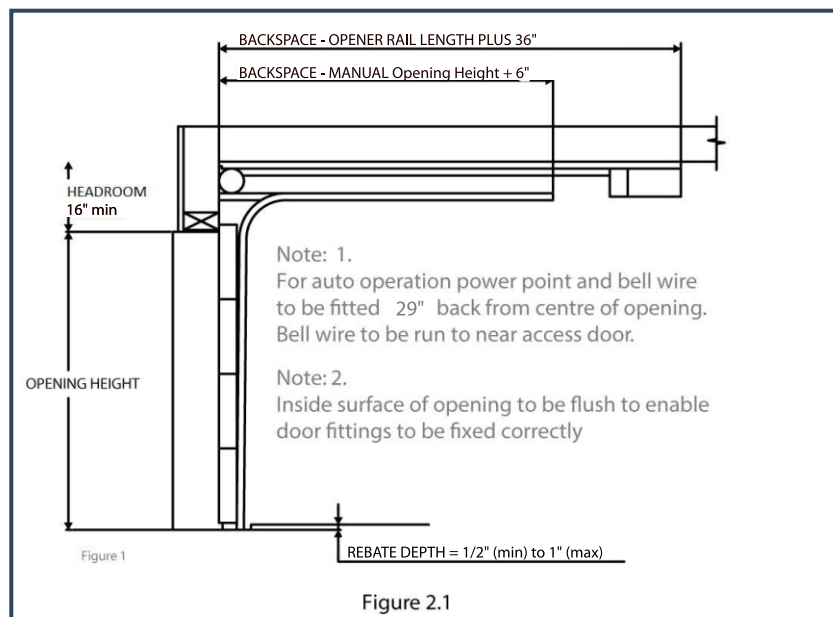

WARNING: No guarantee will be given or responsibility accepted by the manufacturer if the door is not installed as instructed. For satisfactory door operation please follow the instructions carefully.

INSTALLING FLAG BRACKETS

Preparing the Vertical Tracks

- Ensure you have all the components shown in Figure 3.1.
- Ensure the lintel is level.
- Mount vertical track to wall ensuring track is plumb.
- Track spacing should be 1-1/2" wider than the door panels (5/8" per side)

NOTE: Assemble Brackets and Flag Angles with 1/4" x 7/8" track bolts. Do not tighten at this point.

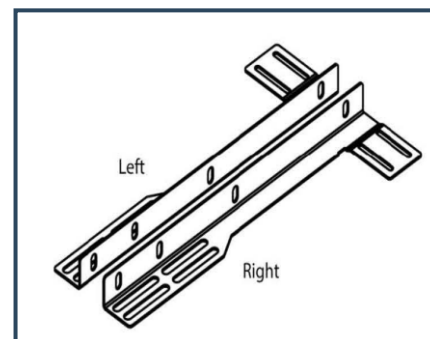
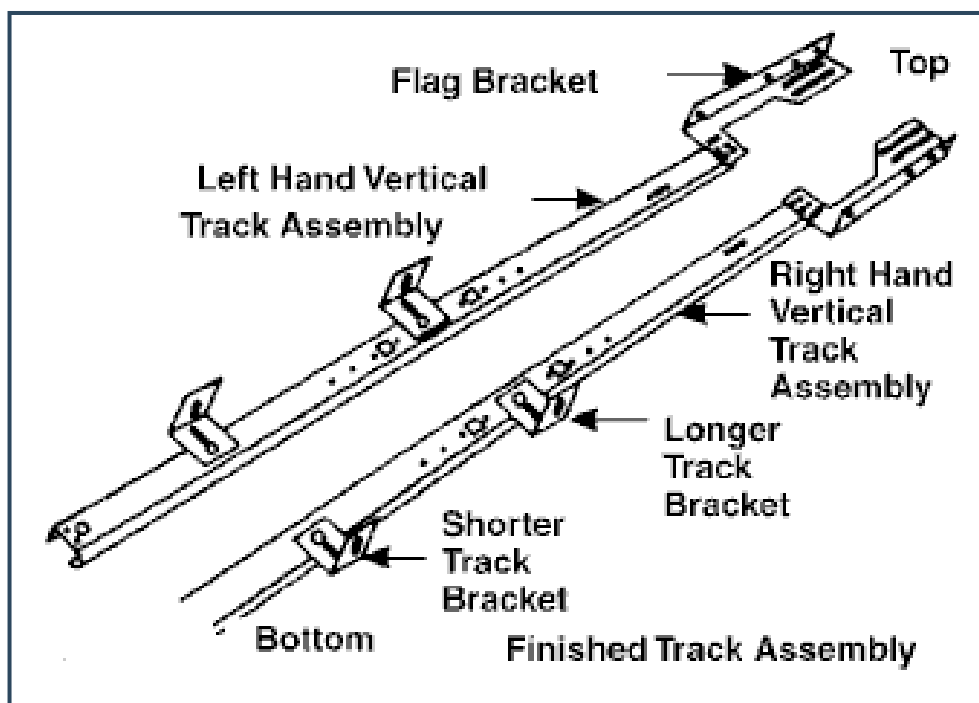

BOTTOM PANEL ASSEMBLY

BEFORE YOU BEGIN ASSEMBLING THE BOTTOM DOOR PANEL

- Ensure you have all the components as shown in Figure 5.1.
- Identify the bottom panel by the retainer at the bottom of the panel.

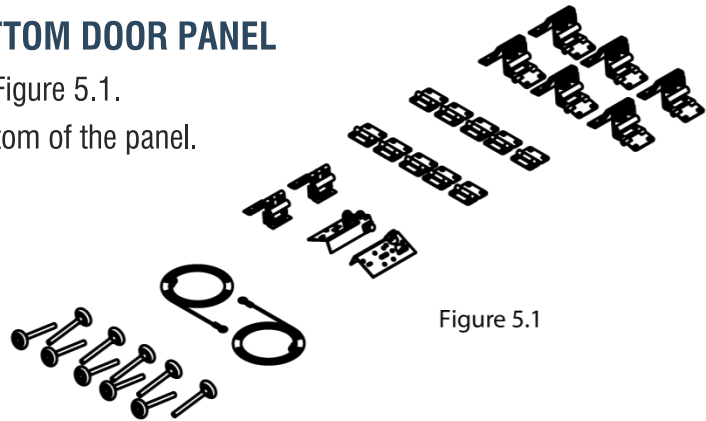

Figure 5.1

ASSEMBLING THE BOTTOM PANEL

Remember to remove protective film from door panels.

- On the right side of the panel, fix the bottom bracket hinge to the bottom corner of the panel using 3 x 3/16 x 7/8 Tek screws and insert roller. Note: the bracket should sit 1/4" up from the weather seal.
- Repeat on the left hand side.
- Fit the #1 side hinges to the top of the panel using 4 x 3/16 x 7/8 Tek screws and insert roller.
- Fix the center hinge to the door using 2 x 3/16 x 7/8 Tek screws. Note: the hinge pivot should sit flush with the top edge of door panel.
- Attach both of the lifting cables by placing the cable loop over the mushroom stud on the bottom bracket.

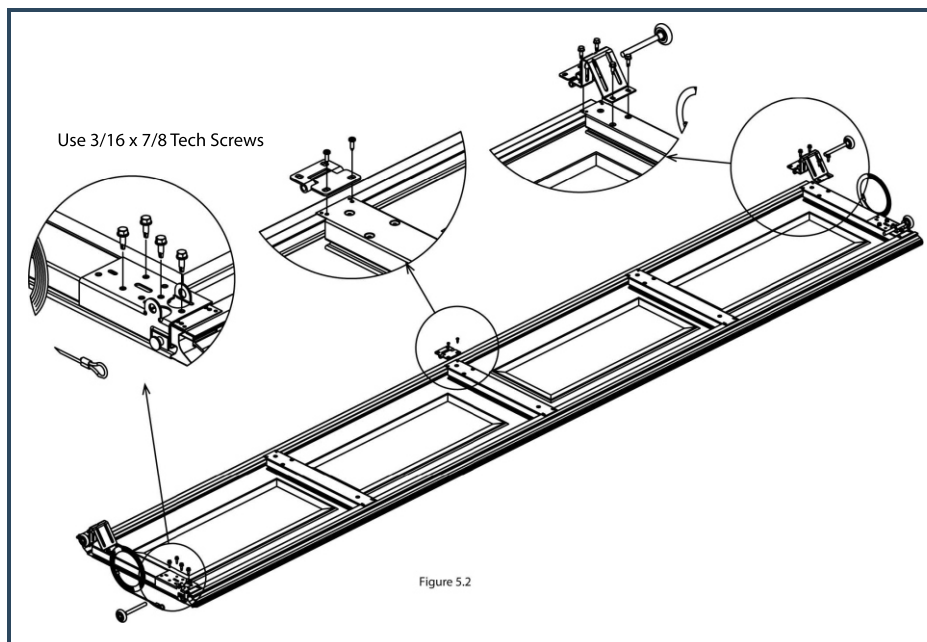
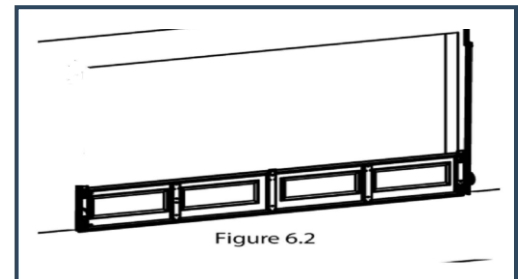

Figure 5.2

BOTTOM PANEL INSTALLATION

HANGING THE VERTICAL TRACKS

- Sit the assembled bottom panel in place evenly across the door opening so that each side of the panel overlaps the door opening evenly as shown in Figure 6.2.
- Ensure the panel is sitting level on the floor. Note level the panel with shims that will extend under the track as well should the floor not be even.



FIXING THE FIRST VERTICAL TRACKS

- Fit one the vertical tracks over the bottom panel wheel assemblies.
- Fix both track brackets to the door jamb using 5/16 x 1 1/2 wood lags or an appropriate fixing so that there is a 5/8" gap between the track and the panel.
- Do not tighten the track bolts at this time.

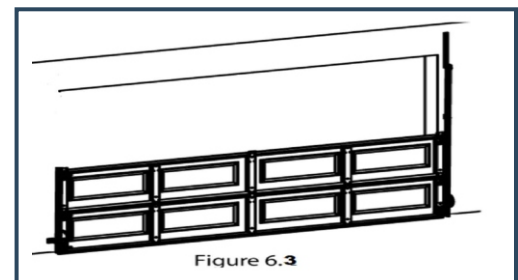

INSTALLING THE DOOR PANELS

Remember to remove protective film from door panels

- Attach the #2 side hinges in the same manner as the bottom panel using 3/16 x 7/8 Tek screws.
- Rotate the panel into position securing the roller into the track and set it into position. NOTE: The door panels should fit neatly together with the tongue and groove configuration.
- Repeat steps a.-b. for all the remaining panels except the top panel as shown in Figure 6.4 using the next sequentially numbered side hinge

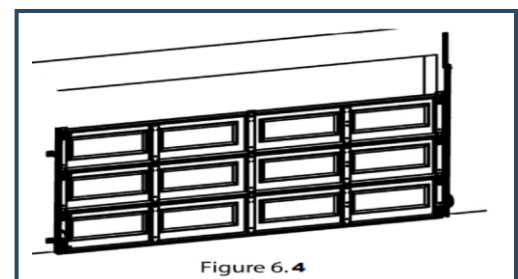

INSTALLING THE SECOND TRACK

Rotate the track around the rollers and set down onto shims and secure brackets to jamb using 5/16x1 1/2" lag screws. Adjust track brackets as necessary to achieve approximately 5/8" of track spacing on both sides. Adjust tracks in their brackets to achieve approximately 1/8" space between the end of the panel and the jamb. Push the flag angles tight to the jamb and tighten their track bolts. Fasten flag angles to the jambs using 5/16x1 1/2" lag screws ensuring that they are plumb and maintain the 5/8" track spacing.

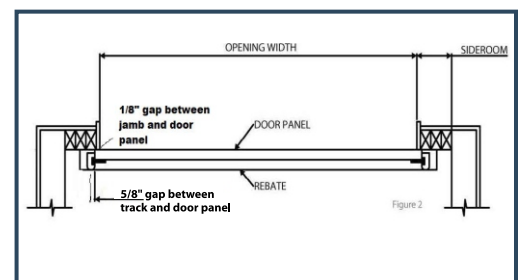

HORIZONTAL TRACK

ASSEMBLING THE HORIZONTAL TRACKS

- Orientate the horizontal and hockey stick tracks on the ground as shown in Figure 7.1.
- Bolt the horizontal and hockey stick tracks together using 3/4 x 7/8 track bolt as shown in Figure 7.1.

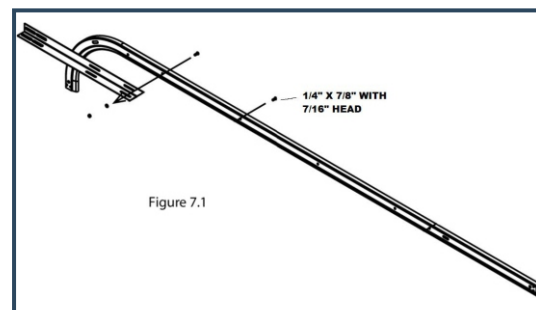

INSTALLING THE HORIZONTAL TRACK ASSEMBLIES

- Fix the horizontal section of the track assembly to the top of the flag bracket using an 3/8x3/4 carriage bolt and 3/8" flange nut.
- Fix the vertical section of the track assembly to the bottom of the flag bracket using 2 x 1/4 x 7/8 track bolt. Note: ensure the vertical and horizontal track assemblies are fitted in line with each other to form one continuous track. (figure 7.2)
- Repeat steps a)-b) on the other side.
- Tighten all track connections.

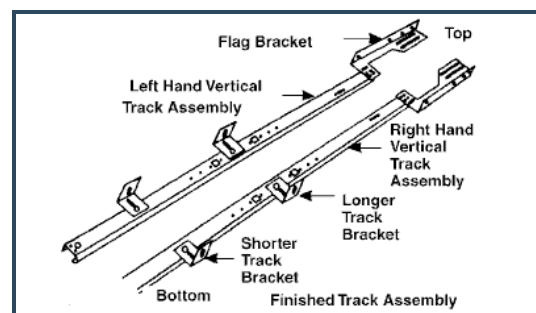

INSTALLING THE CEILING HANGING BRACKET

- Measure from the door opening along the horizontal track to a point approximately 2' less than the door height.
- Identify a solid ceiling fixing point around this point and measure down to the horizontal track.
- Cut the ceiling hanging bracket to length such that the final installed position will leave the horizontal track assemblies level.
- Fix the ceiling hanging bracket to the ceiling using 1/4 x 1 1/2 wood lags screws or appropriate fixing ensuring that lags are securing to structure.
- Bolt the ceiling hanging bracket to the horizontal track using 1/4 x 7/8 track bolt. Note: the final hanging position of the horizontal track assemblies should be level, parallel to each other, and square to the door opening.

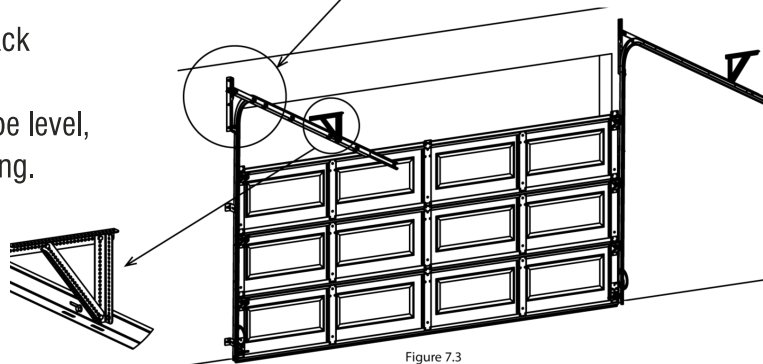
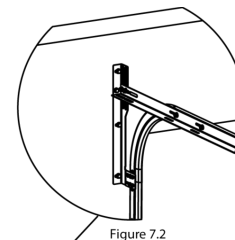
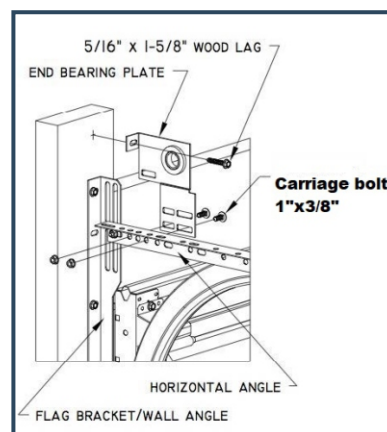

Before you begin assembling the spring axle assembly, layout the spring assembly components as shown in Figure 8.1.

Note: right handed components can be identified by their black markings and left handed components by their red markings.

Parts Checklist

- A. Cable drum: left and right
- B. Spring assemblies: left and/or right
- C. Torsion bar/axle
- D. Side bearing brackets
- E. Spring anchor bracket
- F. Spring bearing

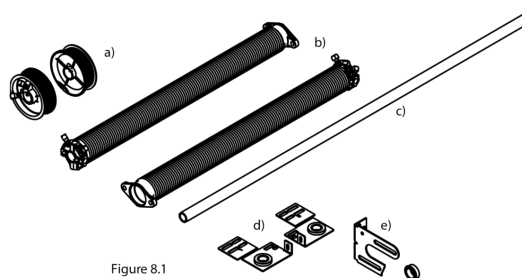

Figure 8.1

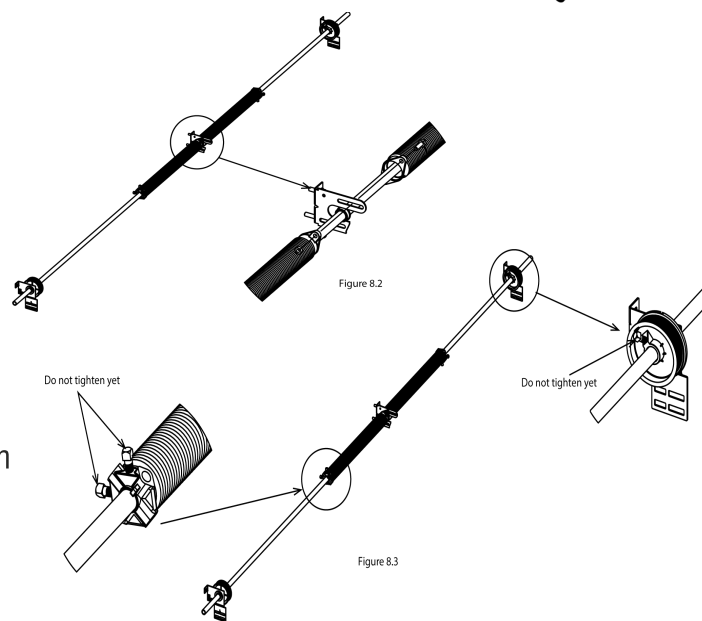
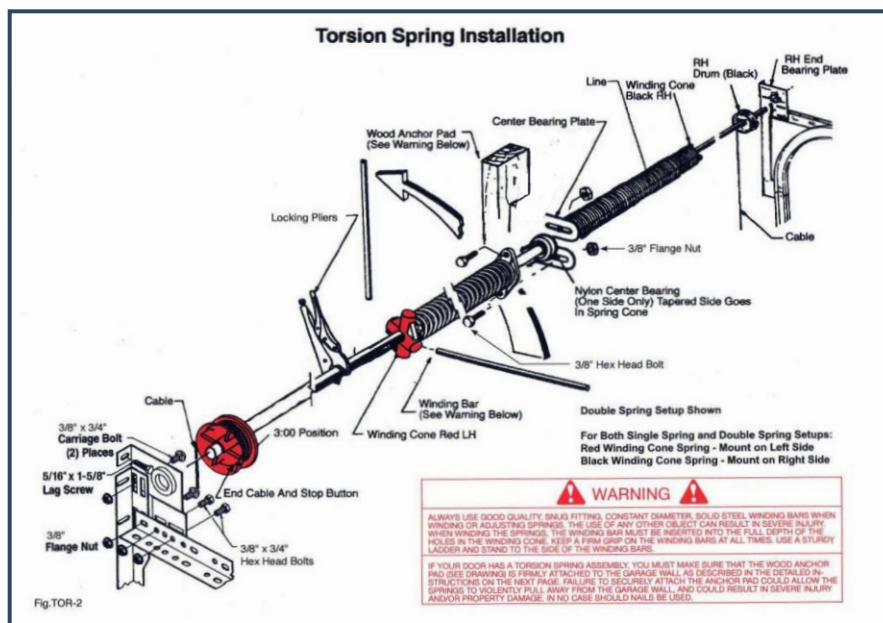

Figure 8.2

Figure 8.3

SPRING AXLE ASSEMBLY

- a. Slide the spring bearing to the middle of the axle.
- b. Slide on the left and right spring in the correct orientation until they are up against the spring bearing.
- c. Place the left and right cable drums on to the axle in the correct orientation.



SPRING AXLE INSTALLATION

- a. Recommended with two people, carefully lift the spring axle assembly and slide it in to position in the end bearings.
- b. Fix the spring anchor bracket approximately to the centre of the lintel using 5/16 x 1 1/2 wood lags or appropriate fastener. Note: this diagram shows how the spring should be installed in low headroom situations. (When sufficient headroom is available set spring(s) from center of door outwards). Should fasten to 2x6 spring pad as detailed on page 1.
- c. Bolt springs to spring anchor bracket using are used with single spring application 5/16 x 1 1/2 with 1/2" head with nuts and washers. Note: some doors are used with single spring application.

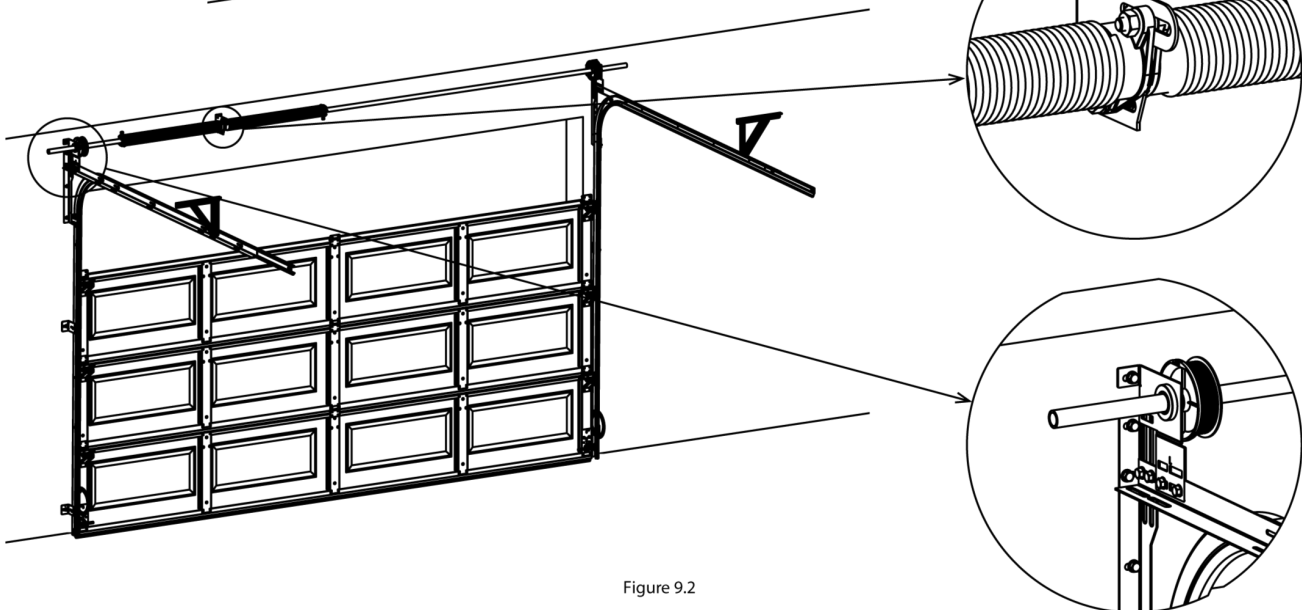
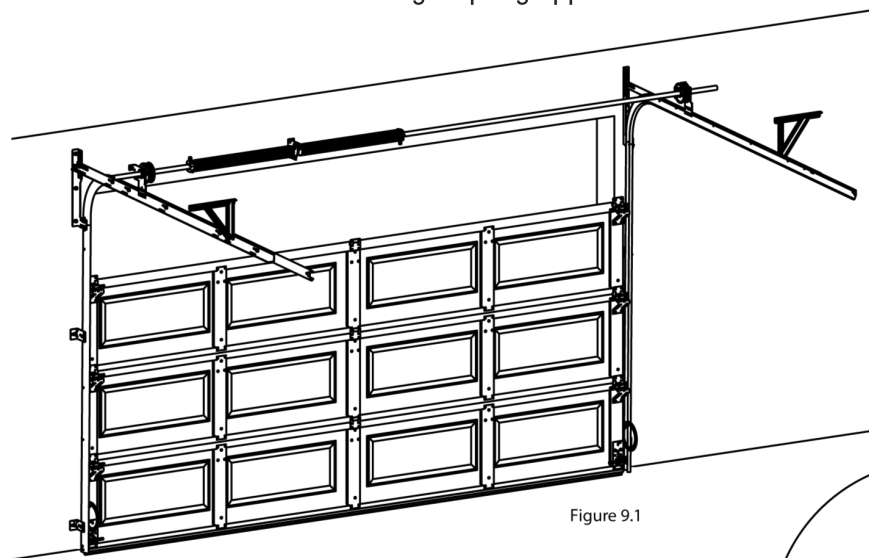

LIFTING CABLE INSTALLATION

- a. Feed the left hand lifting cable behind the door so that the wire is between door frame and roller axles.
- b. Fit the end of the wire into the groove of the wheel drum so that the wire sits flush in the door groove.
- c. Wind the wire on to the drum by rotating the drum clockwise until all the slack in the wire is removed.
- d. Tighten the cable drum grub screws on to the axle using a wrench.
- e. While keeping the wire tight, attach two pairs of vice grips to the end of the axle to secure it in place. Note: the vice grips should be orientated so that one grip is facing upwards and one is facing downwards. This is to ensure the axle doesn't move when tightening the springs, allowing the cables to remain in the correct position.
- f. Repeat A-D for right cable

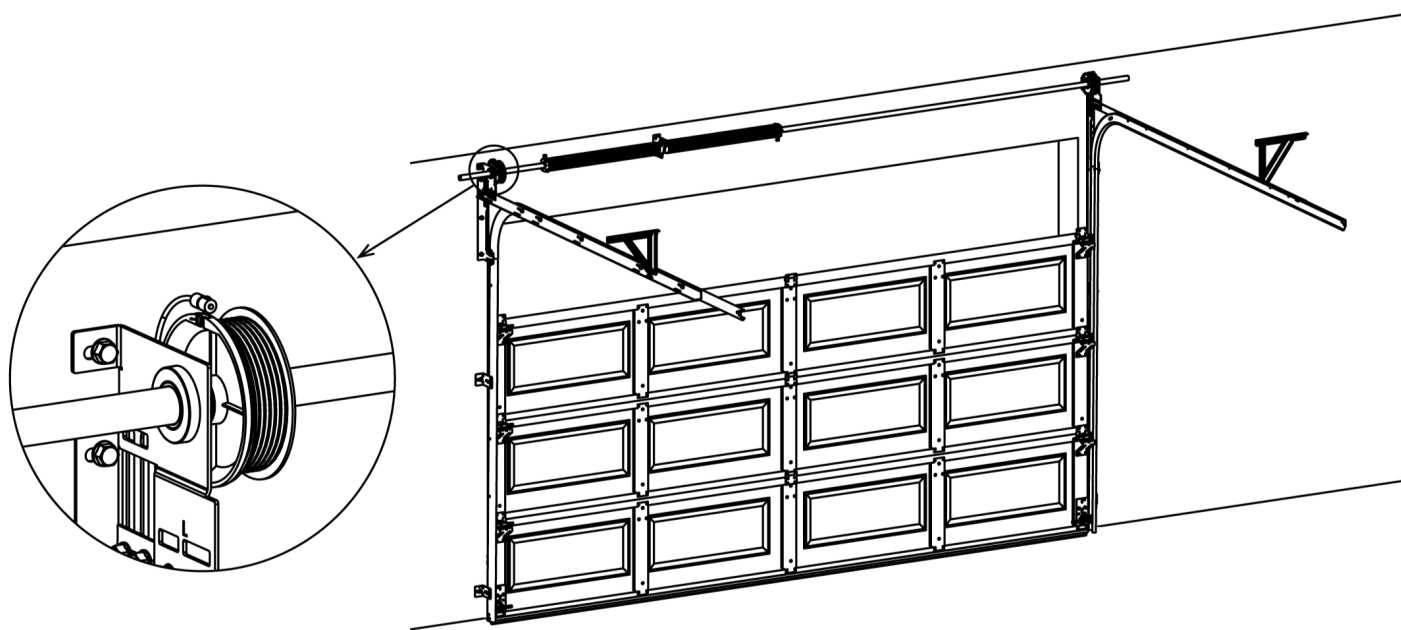
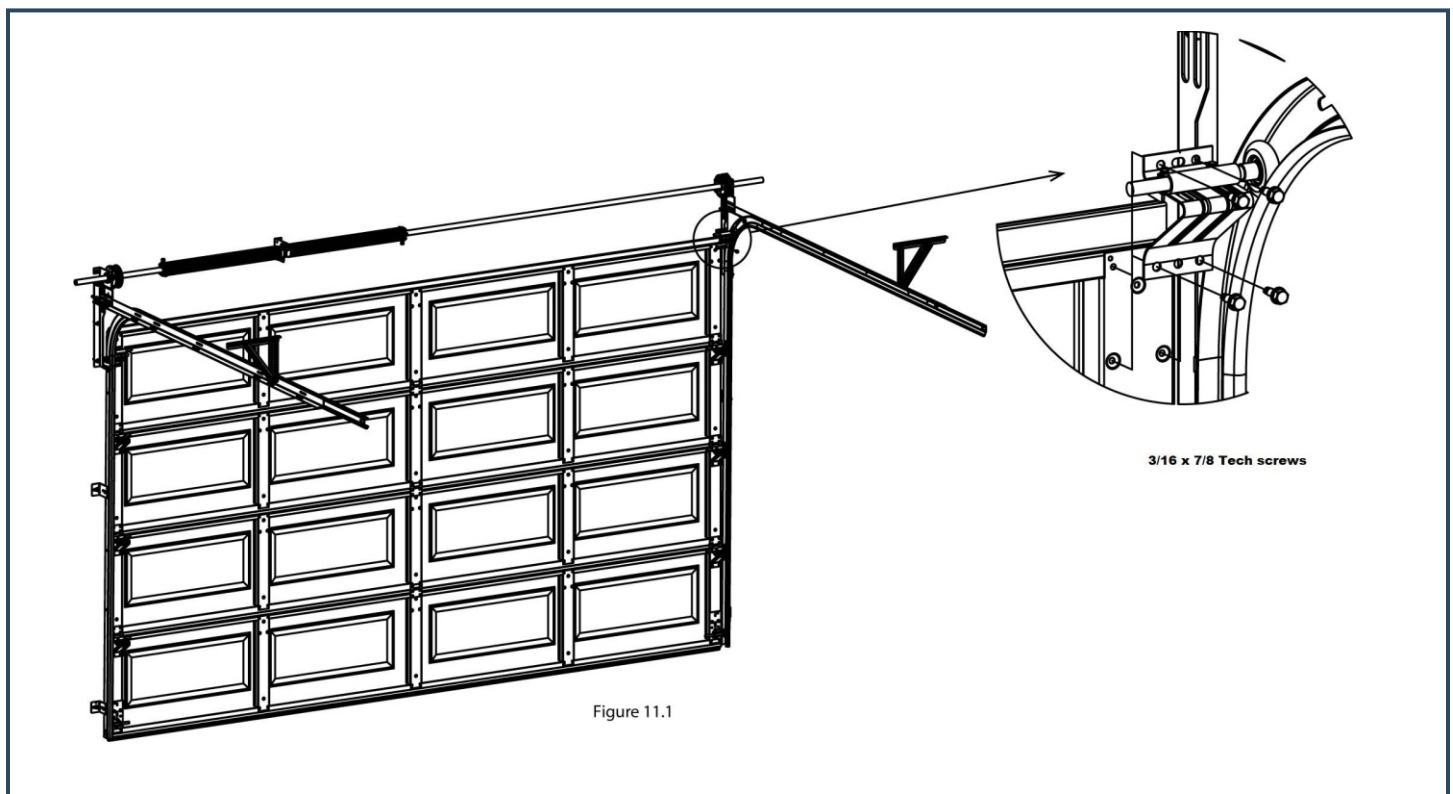

Figure 10.1

TOP PANEL INSTALLATION

- Attach the top fixtures to the top panel 3-1/2" from the top edge with 4-3/16 x 7/8 Tek screws.
- Secure all the panels together by screwing the hinges together with 3/16 x 7/8 Tech screws.
- Adjust top fixtures to achieve 1/8" of space between top of panel and header (lintel).
- Remove one top fixture and set aside. Rotate the top panel into position.
- Set in place and re-install second top fixture.



INSTALLING THE ANTI-SAG STRUT

SECTIONAL GARAGE DOOR - Only on doors 16' wide or wider

- Check all hinges are attached and nuts and bolts are tight.
- Measure and cut the anti-sag strut rail to the door panel width.
- Fix the anti-sag strut rail on the top edge of the top panel with 3/16 x 7/8 Tek screws. Note: the required anti-sag strut is provided in a single length appropriate to the door size. Install on the top panel first and then on to subsequent panels until the supply is exhausted.

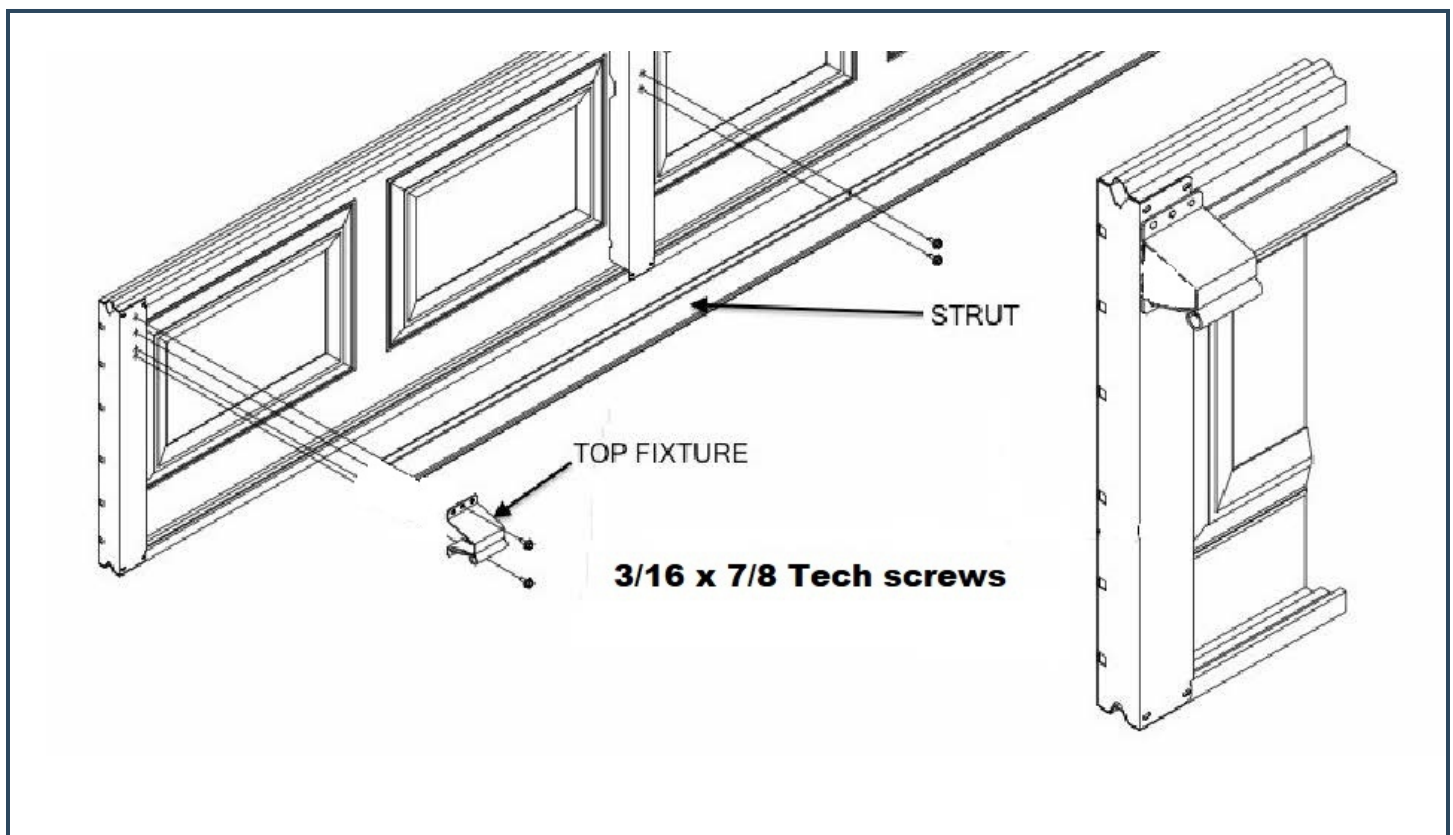

TENSIONING THE SPRINGS

WARNING: Springs under tension are an extreme hazard. Unless you are trained for this application, it is strongly advised that you seek the advice of a trained professional for winding of the springs.

- a. Insert two winding bars into the spring as shown in Figure 13.1. (winding bars not included)
- b. Rotate the bars upwards, ensuring a firm grip is always maintained on at least one of the torsion bars at all times.
Note: to achieve the correct tension, the spring should be wound a full turn for every foot in door height plus one half additional turn.
ie. an 8 foot door will be wound 8-1/2 full turns (occasionally an extra 1/2 turn may be required).
- c. Once the correct tension is achieved, tighten the two set screws with a wrench.

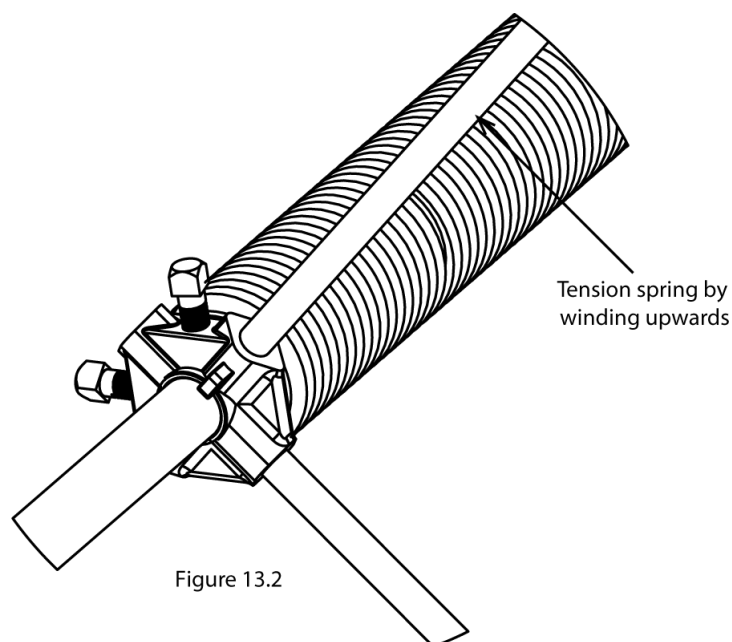
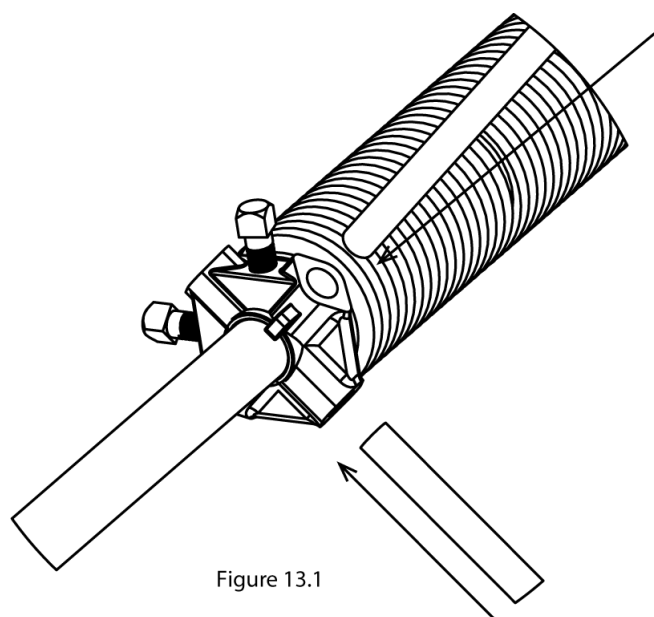

Winding bars not included. You require 2 -1/2"x18" cold rolled steel rods.

FINAL CHECK

Remove the clamps from the axle and test the doors movement. The door should lift up and down with pressure from one hand and be stationary with no added pressure. Refer to the trouble shooting appendix if the door doesn't work properly.



TROUBLE SHOOTING

TORSION BAR MOVING

- Cable drums not adjusted correctly
- Springs not adjusted correctly
- Shaft collar not fitted (single spring)
- Check end bearing brackets are square and vertical

DOOR WILL NOT HOLD UP IN OPEN POSITION

- Adjust tension on door
- Incorrect springs
- Panel reinforcing fitted incorrectly

DOOR NOT LEVEL

- Check level marks are correct
- Lifting cable not equally tensioned

LIFTING CABLES LOOSE WHEN DOOR IS OPENED

- Cable drums have slipped
- Diagonals out of square
- Check length of lifting cables

DOOR MOVING TO ONE SIDE

- Clearance incorrect
- Cable drum not hard up against end bearing brackets

DOOR PANELS JAMMING/RUBBING ON TRACKS

- Incorrect clearance between wheel and vertical track
- Door out of Level
- Cable drum not lined up correctly
- Vertical tracks not parallel
- Lifting cables slipping

DOOR HARD TO LIFT

- Incorrect tension on springs
- Spring may have slipped on set screws
- Wrong spring
- Check all panel reinforcing on door panel



Direct Overhead Door Supply is your door source for residential, commercial, industrial, and agricultural doors in Western Canada.



**Toll free 866-645-1890
Direct 403-786-3039**



4816 45 Street, Lacombe



sales@directoverheaddoor.ca

Opening up opportunities for your business with quality overhead doors

